

OPTIONS

Mounting method

- to be grouted in

Fence mounts

- one-sided
- double-sided
- no

DESCRIPTION

The Olimpia 01.082 post consists of two flat bars made of metal or stainless steel, cross-welded for reinforcement. The metal option is available in various colors from our RAL spectrum. This post is anchored into a concrete base. Its contemporary design and unique shape make it an exceptional choice for any modern urban setting.



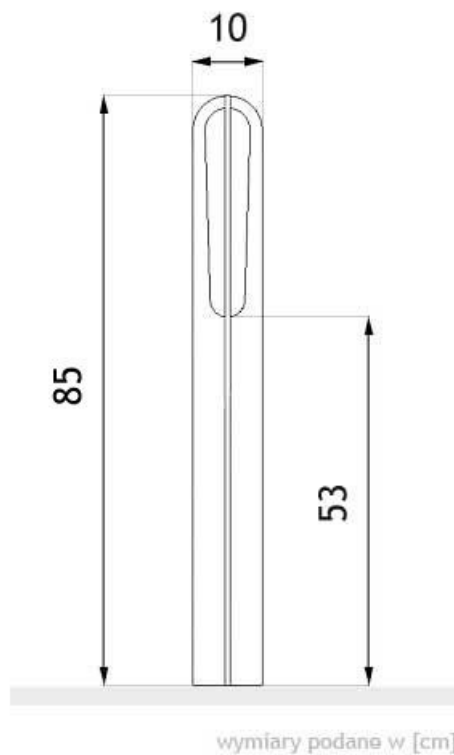

GENERAL TECHNICAL DATA

Dimensions

- width: 4 in
- height from ground surface: 33 1/2 in
- height with anchor section: 49 1/4 in

Materials

- carbon steel or stainless steel

ZANO



M. Welmiński

Product: Olympia post
 Catalog number: 01.082
 Designer:
 Mateusz Welmiński

In accordance with the Polish Law on Copyright and Related Rights of 04.02.1994 (Official Journal of Laws No. 24, item 83, corrected: Journal of Laws No. 43, item 170) and in accordance with the EU copyright legislation including all EU directives and regulations on copyright, Zano Mirosław Zarotynski Company, reserves the copyright of drawings, descriptions, 3D models, renderings, graphics, content contained in offers, attachments to offers and all other documents. Its content is the intellectual property of ZANO Mirosław Zarotynski company. The use of author's ideas, solutions, copying, distribution of photos, graphics or fragments of graphics, descriptive texts, for profit, without the permission of the author - ZANO Mirosław Zarotynski company - is prohibited and constitutes a copyright infringement and is punishable.

NOTE: The drawings do not reflect the actual dimensions of the foundation. These are only sample installation diagrams taking into account the type of anchoring and the material of the substrate to which to attach the furniture.

The size of the foundation depends on local foundation conditions.



INSTALLATION TO PAVING WITH FOUNDATION

Installation description

1. ZANO product
2. Stone paving / concrete paving / stone slabs / concrete slabs
3. Sand ballast (approximately 2 - 4 cm)
4. Concrete foundation of C16/20 class (top surface of concrete 10 cm below paving surface)
5. Local land



MOUNTING TO CONCRETE FOUNDATION

Installation description

1. ZANO product
2. Concrete foundation of C16/20 class (top surface of concrete 10 cm below paving surface)
3. Local land



MOUNTING TO CONCRETE FOUNDATION

Installation description

1. ZANO product
2. Fixed restrained surface, such as concrete or asphalt
3. Concrete foundation of C16/20 class (top surface of concrete 10 cm below paving surface)
4. Stone aggregate substructure
5. Sand ballast (approximately 2 - 4 cm)
6. Local land